

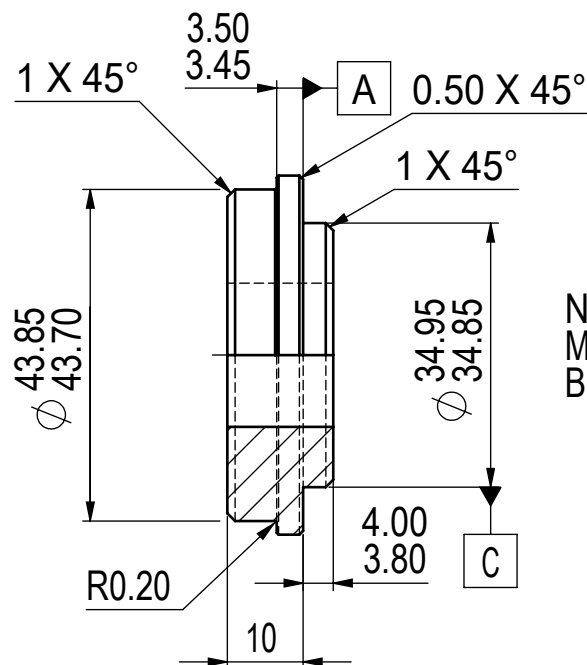

ISOMETRIC VIEW FOR ENG REF
ONLY NOT TO SCALE

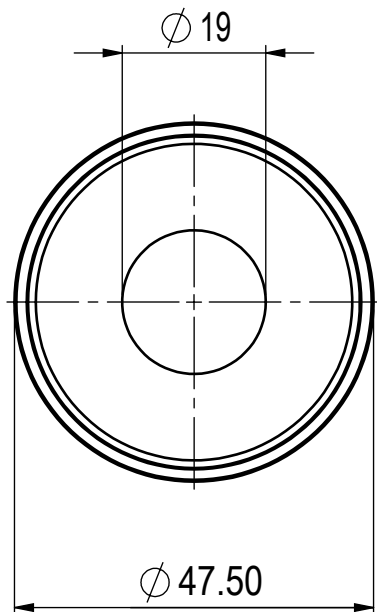

NOTE 34.95/34.85 DIM
MATES WITH COMPONENT
BML HS001

IF IN DOUBT ASK FOR CLARIFICATION

DRAWING TO BS8888

COMPONENT WEIGHT 69.72 GRAMS

TOLERANCE	0.0	±0.25	CAST	±1.0
	0.00	±0.10	DRAFT	3° TYP
	0.000	±0.05	ANGULAR	±0.5

FINISH	TURNED MILLED BORED	3.2µm
	REAMED	0.8µm
	GROUND HONED	0.4µm

3D CAD	MMC	15/02/2015
DRAWN	DRG DRAWN	01/01/2015
APPVD	DRG APPROVED	01/02/2015

FINISH/TREAT/SPEC
SEE MACHINING INSTRUCTIONS

3D CAD MODEL TO BE TREATED AS MASTER	CASTING'S, FORGING'S AND COMPOSITE MOULDINGS TO BE FREE FROM POROSITY AND VOIDS SEE DETAIL SPECIFICATION
DXF AND PROFILE CUTTING TOLERANCE	

PUB REL	Y
DEV REL	N

MATERIAL	303 ST-ST FREE MACHINING
SPECIAL INSTRUCTION	

MATERIAL
303 ST-ST FREE MACHINING

INTERNAL METRIC 6g	INTERNAL IMP 2a	NON HARD ANODIZING TO ISO 7599
EXTERNAL METRIC 6H	EXTERNAL IMP 2B	HARD TYPE III TO ISO 10074
		SEE DETAIL IF OTHER

SIEMENS NX	DASSAULT SYSTEMES
------------	-------------------

MIL-TFD-41	
------------	--

MIL-TFD-41

STER
SUPERTOOLROOM
UNIT 4, SPRINGVALE TRADING EST
PENISTONE, SHEFFIELD, ENGLAND S366HH
INFO@BICYCLEMANUFACTURING.CO.UK

DWG TITLE/PART NAME
HEADSET PUCK 44MM REYNOLDS TOL

DWG No:
BML HSP 001

REMOVE ALL BURR'S SHARP EDGES

DO NOT SCALE DRAWING 1:1@A4

ALL DIMENSIONS IN mm U.O.S



01
REVISION